

SERIES 1700**PRECISION PNEUMATIC FLOW REGULATORS****1735****1721****1713/4/5**

- AVAILABLE WITH BUBBLER, FLOW METER OR NON-INDICATING
- ALUMINIUM OR STAINLESS STEEL
- HIGH ACCURACY

HNL's precision flow regulators are suitable on many applications where a constant flow of air is required. These applications include use in level measurement where a constant flow of air is required to a dip tube, or in purging applications.

High stability closed loop flow control is an integral part of the construction. The flow regulator maintains a constant differential pressure across an orifice to maintain a flow rate that is independent of the inlet or outlet pressure (typically the flow rate will vary by only +/- 1% for a 1 bar change in differential pressure across the regulator). The orifice size is controlled with a needle valve thus providing simple adjustment of the required flow rate.

Series 1713/4/5

These regulators are supplied fitted with a variable area flow meter (accuracy +/- 2% of full scale) to enable a precise flow rate to be achieved. The three ranges available are 1 to 30 NI/hr, 10 to 100 NI/hr and 30 to 300 NI/hr. For correct operation the flow meter must be above the regulator (as shown).

Series 1721

This regulator is supplied fitted with a bubbler flow indicator. The acrylic tube below the regulator is half filled with a suitably dyed liquid through which the regulated air flow bubbles. Flow rate adjustment is from 0.5 to 3 NI/hr. For correct operation the bubbler must be below the regulator (as shown).

Series 1735

This regulator is supplied with no flow indicator. It may be suitable for use on applications where a separate flow meter is fitted or perhaps with a dip tube where the flow rate can be established by noting the bubbling rate of the dip tube directly. Flow rate adjustment is from 0.5 to 300 NI/hr. This regulator will operate correctly when mounted at any angle.

All three models may be site or panel mounted and are available manufactured in anodised aluminium or stainless steel. N.B. NI/hr = Normal Litres per hour.

MANUFACTURED IN THE U.K.**QUALITY ASSURANCE**

Designed and manufactured by HNL in accordance with BS EN ISO 9001:2000.



Materials (Aluminium Models)	
Body:	Anodised aluminium
Paint finish of flow indicator protection housing:	Epoxy hardened stoved enamel
Internal components:	Anodised aluminium and stainless steel
Materials (Stainless Steel Models)	
Body:	316 stainless steel
Internal components:	Stainless steel
Materials (All Models)	
Diaphragms and seals:	Nitrile
Valve seat:	Viton
1713/4/5 Flow meter:	Meter tube: glass, float: anodised aluminium
1721 Bubbler Tube:	PMMA (Polymethyl Methacrylate)

Specifications							
Pressure Ratings: (Proof rating = 1.5 x MWP)	<table border="0"> <tr> <td>1713/4/5</td> <td>8 Bar MWP</td> </tr> <tr> <td>1721</td> <td>8 Bar MWP</td> </tr> <tr> <td>1735</td> <td>16 Bar MWP</td> </tr> </table>	1713/4/5	8 Bar MWP	1721	8 Bar MWP	1735	16 Bar MWP
1713/4/5	8 Bar MWP						
1721	8 Bar MWP						
1735	16 Bar MWP						
Temperature Ratings:	-20°C to +80°C for dry gases						
IP Rating:	IP66						
Pneumatic Connections:	1/8" NPT INT.						

Series 1713/4/5

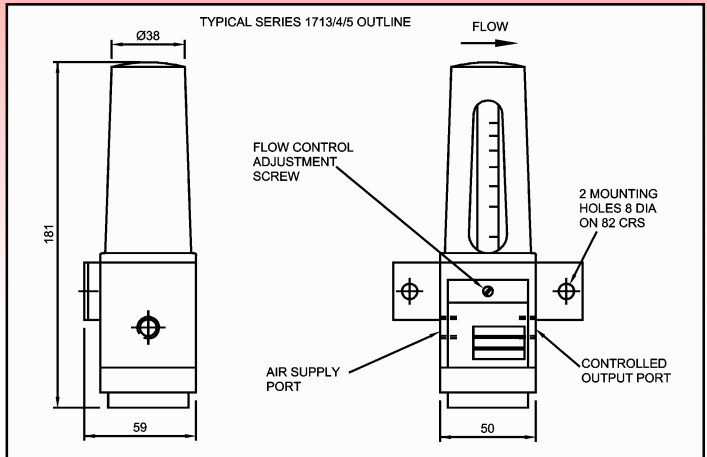

Series 1721

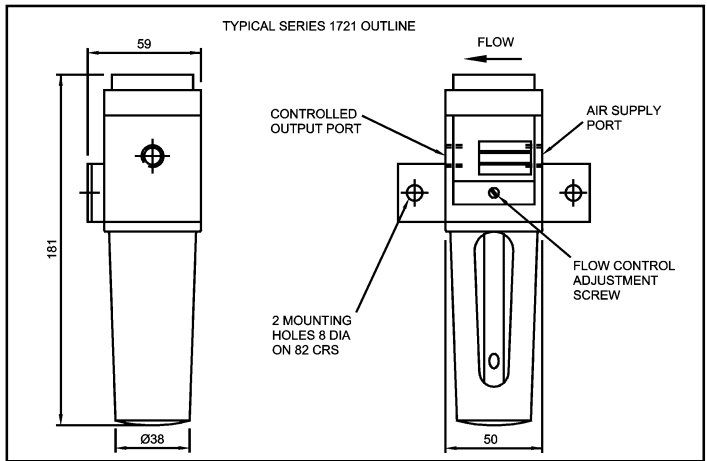

Series 1735

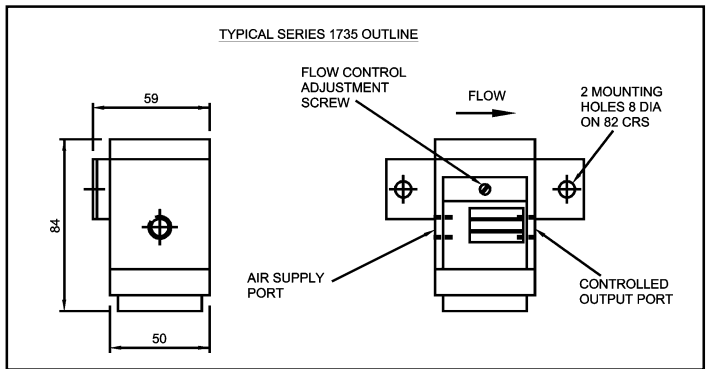

Coding:

1713 - 1 1 0 3

Models

Flow Meter - 1 to 30 NI/hour
Flow Meter - 10 to 100 NI/hour
Flow Meter - 30 to 300 NI/hour
Bubbler Flow Indicator
Non-indicating Flow Regulator

1713
1714
1715
1721
1735

Materials

Anodised Aluminium Construction
Stainless Steel Construction

1
5

HNL ENGINEERING LTD
Instruments & Controls
Precision Machining
Manifolds & Valves

Teesside Industrial Estate
Thornaby-on-Tees TS17 9LT UK
Tel: +44 (0)1642 765553
Fax: +44 (0)1642 762899
Email: sales@hnl-uk.com
Website: www.hnl-uk.com

HNL Engineering Ltd comprises three Divisions offering a wide range of products & services which includes:

Instruments & Controls

Pressure, DP and Temperature Switches & Transmitters. Rotary and linear positioners. Flow regulators & Bubblers. Control Systems.

Precision Machining

Turning, Milling, Drilling, Tapping, Sawing, Welding, Painting, Anodising. From small to large batch sizes in a wide range of materials.

Manifolds & Valves

Wide range of distribution manifolds in both anodised aluminium and stainless steel. Stainless steel ball valves.

The information contained in this data sheet may be changed without notice.